

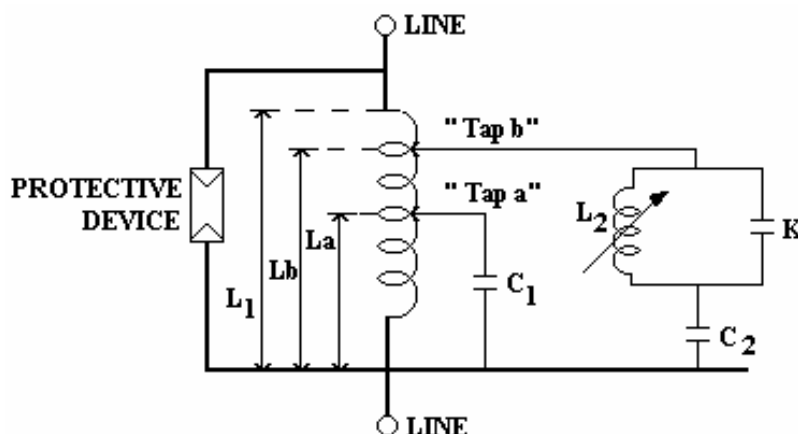

FUNCTION	EMISSION	APPROVAL	VERSION	CONTROL
ORGAN	SETEL	SETEL	January 06, 2006	SEATE
CHECKED	Vagner Lúcio	Flávio Spressola	No. 13842/201 - 2ª Edition	Rodrigo Marcos
INSTRUCTION MANUAL FOR DOUBLE FREQUENCY - TUNING DEVICE ADJUSTABLE IN THE RANGE OF 70- 200 kHz				Total of pages 12 Page 1

1.0 - DESCRIPTION OF CIRCUIT



In the two frequency trap (shown above) there are two parallel resonant circuits: $L_a - C_1$ and $L_2 - C_2$. There are both resonant at the upper frequency f_1 . The $L_a - C_1$ circuit consists of a capacitance which can be varied in steps and an inductance which can be varied continuously by changing the winding of the main coil.

The high impedance of $L_a - K$ circuit prevents C_2 from shunting the $L_a - C_1$ circuit at f_1 .

At the lower, frequency f_2 , the entire lower branch, K in series with $L_2 - K$ that C_1 tunes the trap to the lower frequency, f_2 , inductance L_b (shown above) is that amount of the main coil L_1 actually enclosed in the f_2 circuit L_b is continuously variable in the same manner as L_a , in the f_1 circuit.

2.0 - ADJUSTMENT

2.1 - The tuning charts on pages 9 to 12 provide nominal capacitance values and approximate L_2 tap settings. No calculations are required. A particular tuning area is located by the point where the capacitance values and tap settings are then read from a table. It should be noted, however, that the capacitance tolerances will affect the tuning, for this reason, it is sometimes necessary to go a neighboring tuning area from the one where the frequencies intersect. This is described in more detail later

2.2 - 70 - 200 kHz TUNING CHARTS

Figure on page 8 provide tuning information in the 70 - 200 kHz frequency range. The horizontal line at 200 kHz on the f_1 scale shows the nominal upper frequency limit for f_1 . The vertical dotted line at 70 kHz had shown the nominal lower frequency limit for f_2 . The diagonal dotted line represents the nominal lower frequency limit of f_1 for each value of f_2 , or the nominal upper frequency of f_2 for each value of f_1 . The area enclosed by these three lines is the nominal tuning area of the traps. The regions outside the triangular area can be used with certain limitations. In the regions directly below the triangle, the frequency spacing is less than the recommended minimum, tuning may be more difficult, and the trap bandwidth might be reduced. The rest of the region outside the triangle represents the range in which capacitors tolerance could make it impossible to tune the trap to the desire frequency.

2.3 - Figure below shows atypical curve for two-frequency traps.

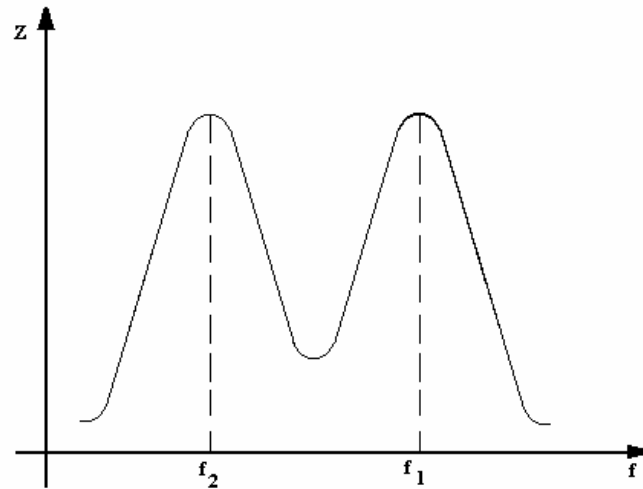

2.4 - In general, the total bandwidth of the two peaks approaches that of the bandwidth of one peak of a single-frequency trap tuned to the geometric mean of the two frequencies, that is $\pm 5\%$ from $\sqrt{f_1 \times f_2}$ considering a 400Ω impedance. If the adjustment charts in this book are followed, the two peaks are usually of approximately equal bandwidth. Occasionally, unfavorable tolerance of the tuning capacitors results in undesirable unequal peaks. Or are equal, but unequal peaks are desired in order to favor a wide band carrier channel at expense of a narrow band channel. The re-adjustment procedure included in either of the next two sections may then be tried to obtain area distributions more suitable for the application. This procedure has the objective of transferring area from one curve to the other. It present a choice of three methods, each of which must be tried to determine if tuning at the desired frequencies can be obtained with the method, and which method gives best results.

2.5 - To Transfer Bandwidth from f_1 to f_2

2.5.1 - Mark the position of the C1 tap on L1 for future reference. Choose the next larger value of C1 and re-tune C1-L1 to f_1 by tapping C1 further down on L1. Mark the tap location for future reference.

2.5.2 - Starting with the original adjustments, choose the next smaller value of C2. Re-tune to f_2 by tapping C2 higher up on L1. Mark the tap location for future reference.

2.5.3 - Starting with the original adjustments choose the next larger value of K. Re-tune L2 obtain the f_1 dip. Adjust the C2 tap higher on L1 to obtain the f_2 dip. If the larger value of C2 and again adjust C2 tap.

2.6 - To transfer bandwidth from f_2 to f_1

2.6.1 - Mark the position of the C1 tap on L1 for future reference. Choose the next smaller value of C1 and re-tune C1-L1 to f_1 by tapping higher on L1.

Title: Instruction Manual for Double Frequency -Tuning Device Adjustable in the Range of 70-200 kHz			
Ref.: Instruction Manual	No.: 13842/201	Rev.: 2	Page: 3/12

2.6.2 - Starting with the original adjustments, choose the next larger value of C2. Tap C2 further down on L1 to obtain the f_2 dip. Mark the tap location for future reference.

2.6.3 - Starting with the original adjustments, choose the next smaller value of K. Re-tune L2 to obtain the f_1 dip. Adjust the C2 tap lower on L1 to obtain the f_2 dip. If the dip cannot be reached use the next smaller value of C2 and again adjust C2 tap.

2.7 - Minimum spacing between f_1 and f_2

2.7.1 - It is generally desirable that each impedance peak be symmetrical. As the spacing is reduced, dissymmetry is introduced. This is quite evident in case of extremely close spacing in figure 15a. This effect is aggravated by having the C1 and C2 taps too far down on L1 due to careless adjustment.

2.8 - Adjustment

2.8.1 - Locate the upper frequency, f_1 , on the vertical axis of the chart, and draw a horizontal line through the point.

2.8.2 - Locate the lower frequency, f_2 , on the horizontal axis of the chart, and draw a vertical line through the point.

2.8.3 - Note the lettered area in which the two intersect.

2.8.4 - Locate the letter in the case table, and make the specific connections for C1, K, C2 and L2.

2.8.5 - Disconnect the Lb tap so that the circuit consists of only La and C1 (See figure on page 2).

2.8.6 - Make test connections as recommended by the IEC 353 Standards for single-frequency trap adjustment. (See figure below).

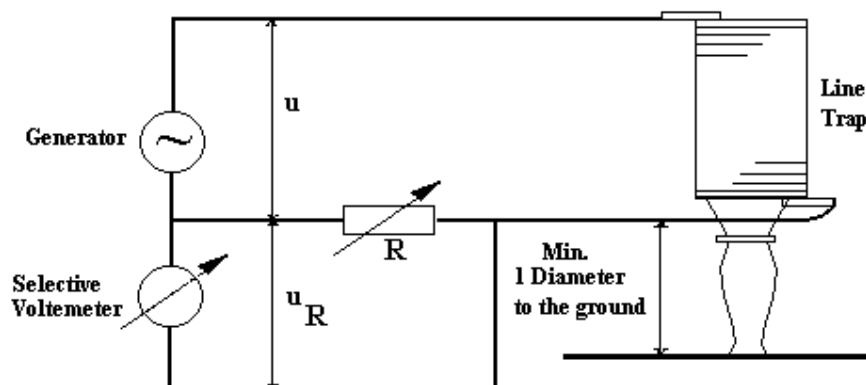

2.8.7 - With the coil tap La on any convenient point, locate the actual resonant frequency by varying the signal generator frequency so that a minimum voltmeter reading is obtained.

Title: Instruction Manual for Double Frequency -Tuning Device Adjustable in the Range of 70-200 kHz			
Ref.: Instruction Manual	No.: 13842/201	Rev.: 2	Page: 4/12

If the actual frequency is higher than, the required frequency, move the tap in direction of more windings turns.

- 2.8.8** - If the actual frequency is lower than the required frequency, move the tap in direction of decreased number of winding turns.
- 2.8.9** - If a case should arise (due to capacitance tolerance) where the full coil is in the circuit and the frequency is still too high, select the next high nominal value of C1 and readjust the coil tap.
- 2.8.10** - It is desirable to have as much of the main coil inductance in the circuit as possible. Thus, is the tuning tap is set very far away from the tuning pack end of the trap, a smaller value of C1 should be chosen and the tap re-adjusted to determine whether the trap can be tuned for the lower value of C1. Due to capacitor tolerances and the limited number of capacitance steps available, it may necessary to lose considerable inductance by tapping down on coil. However, as long as the specified 400 Ω impedance is obtained over the bandwidth, the trap is operating satisfactorily. In this case of adjustable tuning from 70 to 200 kHz the bandwidth should be at least \pm 5% of the geometric mean frequency of adjusted band.
- 2.8.11** - Connect the "tap b" to any convenient point the main coil.
- 2.8.12** -Without changing the signal generator setting adjust the core of the coil L2 until a minimum voltage U_r is obtained. This tunes the L2-K circuit to frequency f_1 .
- 2.8.13** - Vary the signal frequency until another resonant dip is located on a lower frequency f_2 .
- 2.8.14** – If this dip is below the desired f_2 frequency, move the Lb tap in the direction of decreased inductance and repeat step 2.8.13.
- 2.8.15** - If the dip of step 2.8.13 is above the desired f_2 frequency, move the Lb tap in the direction of increased inductance and repeat step 2.8.13.
- 2.8.16** - Repeat steps 2.8.13. through 2.8.15. until f_2 frequency is obtained.
- 2.8.17** - If a case should arise (due to capacity tolerances) where the full coil is in the circuit, and the actual frequency is still too high, refer to the adjacent area to the left of the original area on the tuning chart.
- 2.8.18** - Make the connections this area specifies for K, C2 and L2. (In many cases, only C2 will need to be changed).
- 2.8.19** - If necessary, re-tune the L2-K circuit to the upper frequency, f_1 .
- 2.8.20** - Tune the trap to the lower frequency, f_2 , using the steps from 2.8.13 to 2.8.16.
- 2.8.21** - If the final setting of the Lb tap occurs at a point which is far below 70 percent of the full coil turns, refer to the adjacent area to the right of the original area.
- 2.8.22** - Proceed as in steps 2.8.18 through 2.8.20.

Title: Instruction Manual for Double Frequency -Tuning Device Adjustable in the Range of 70-200 kHz			
Ref.: Instruction Manual	No.: 13842/201	Rev.: 2	Page: 5/12

2.8.23 -If it is not possible with this set-up to tune the desired f_2 frequency even with the Lb tap in the maximum position, then return to the original chart area and reconnect the circuits K, C2 and L2, adjusted to the original settings.

CIRCUIT A

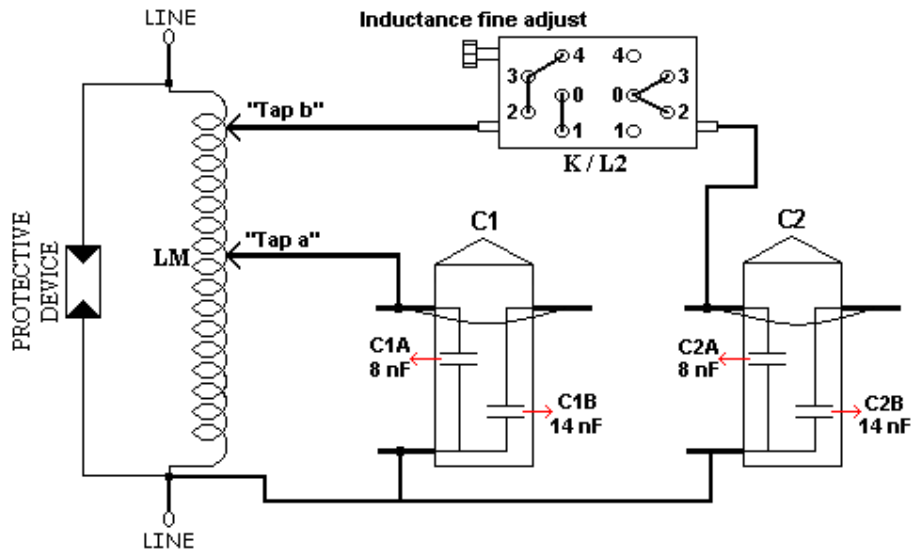

CIRCUIT B

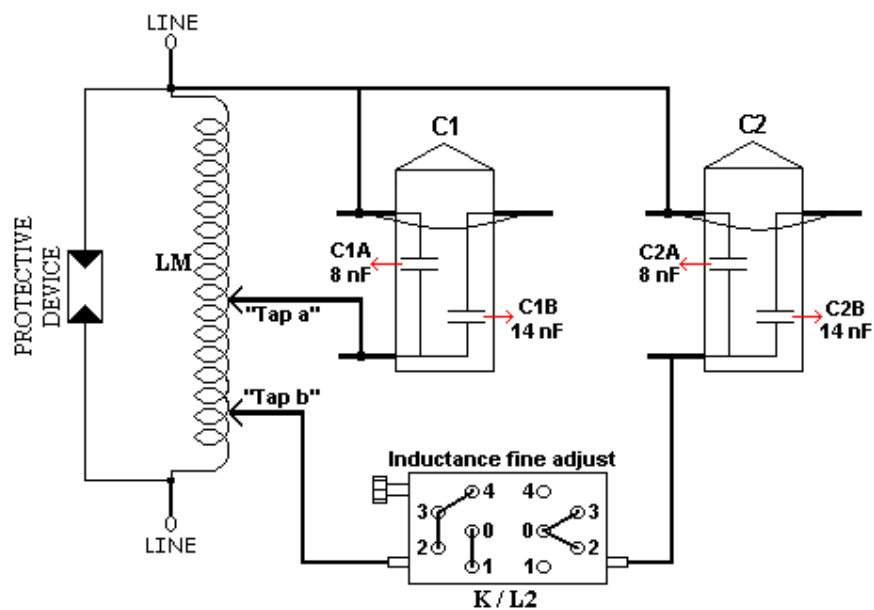

The tuning devices can be connected to circuit A or circuit B

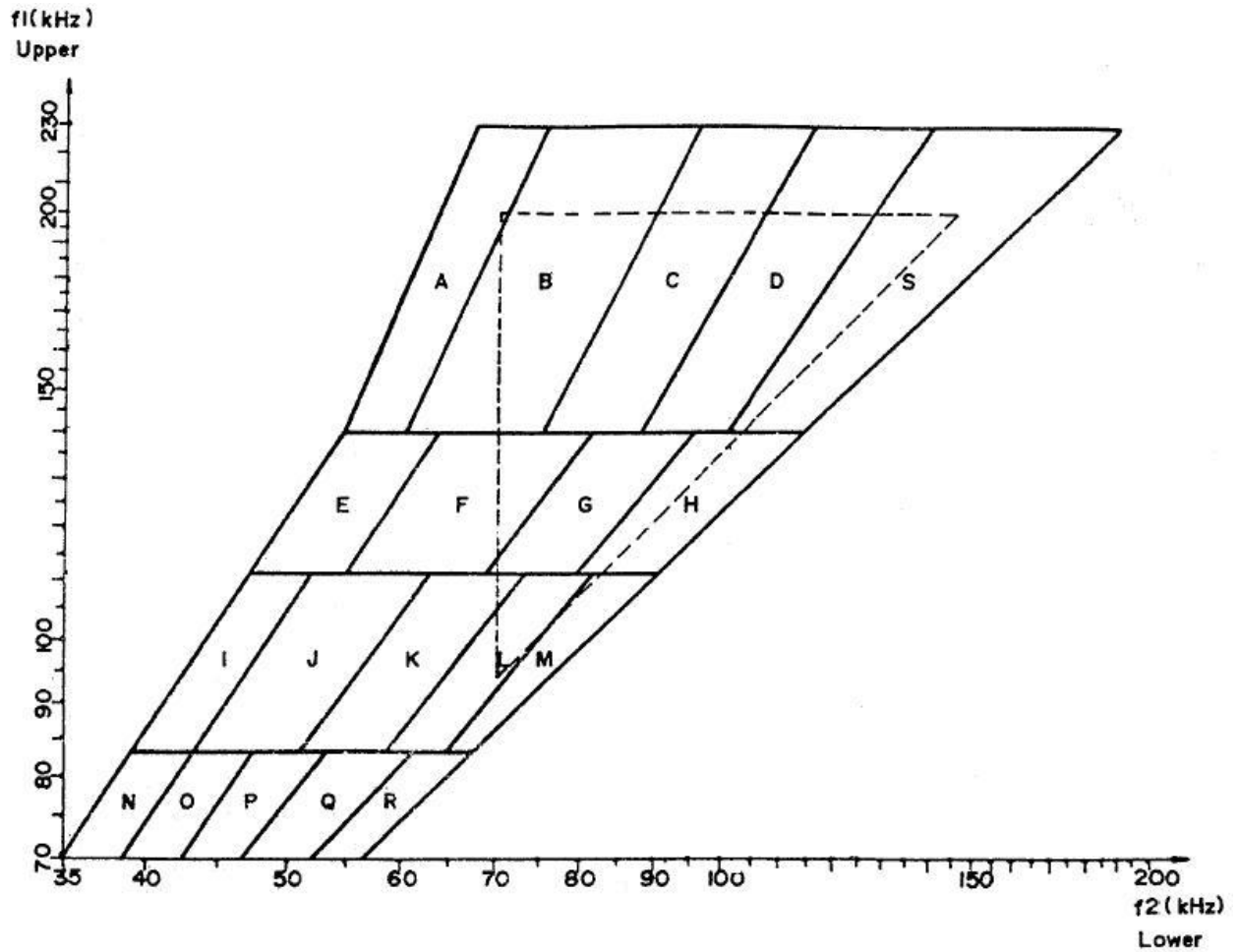

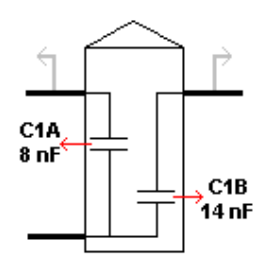
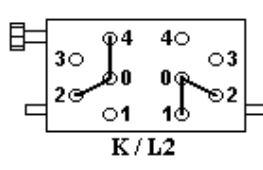
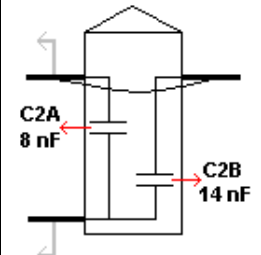
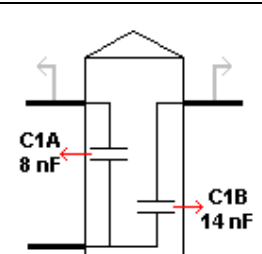
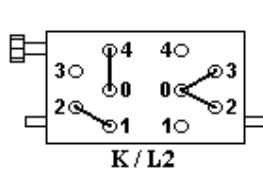
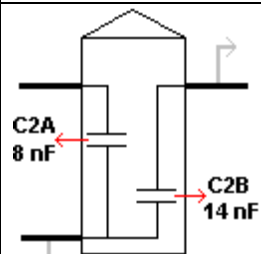
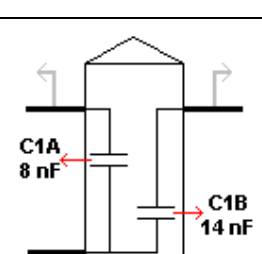
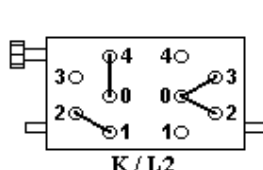
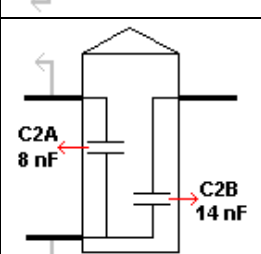
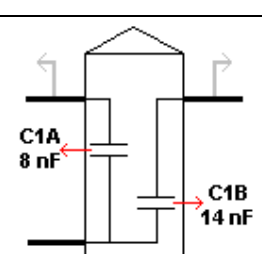
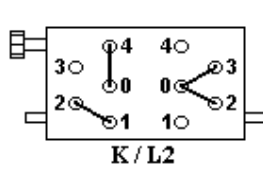
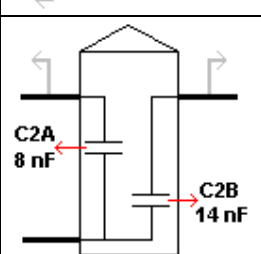
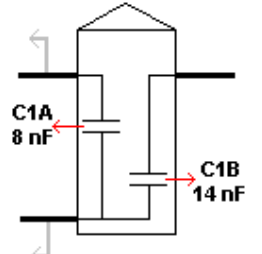
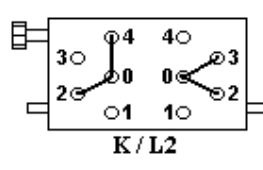
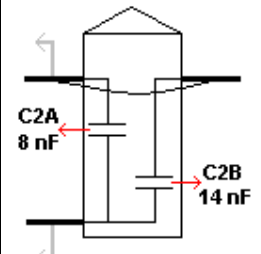
Diagram's Camp	C1		K	L2	C2	
	nF	Connection			nF	Connection
A	5.1		15	 Tap 1 or 2	22	
B	5.1		10	 Tap 2 or 3	14	
C	5.1		10	 Tap 2 or 3	8	
D	5.1		10	 Tap 2 or 3	5.1	
E	8		15	 Tap 2 or 3	22	

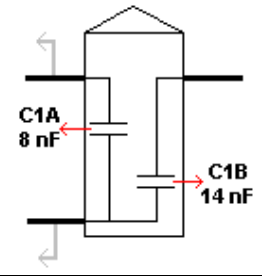
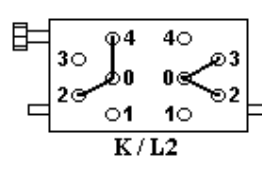
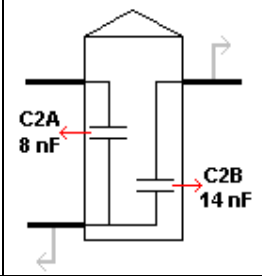
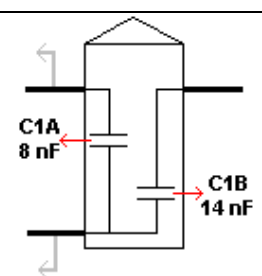
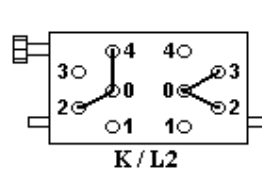
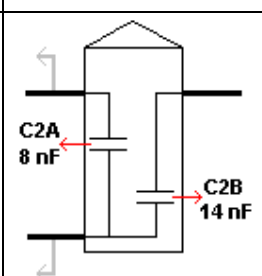
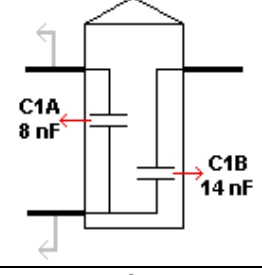
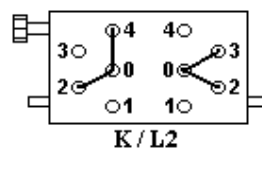
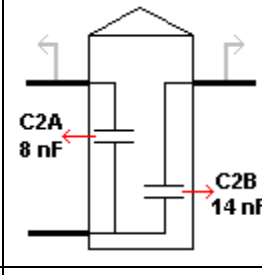
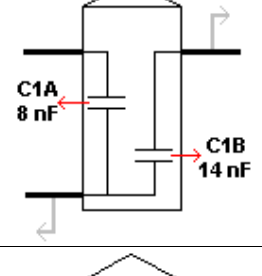
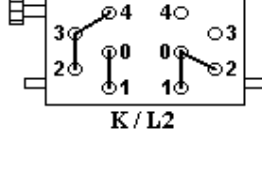
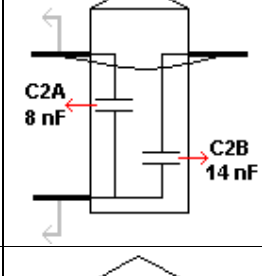
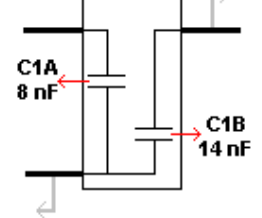
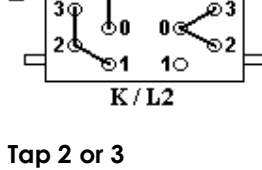
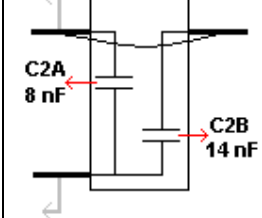
Diagram's Camp	C1		K	L2	C2	
	nF	Connection	nF	Connection	nF	Connection
F	8		15	 Tap 2 or 3	14	
G	8		15	 Tap 2 or 3	8	
H	8		15	 Tap 2 or 3	5.1	
I	14		40	 Tap 1 or 2	22	
J	14		25	 Tap 2 or 3	22	

Title: Instruction Manual for Double Frequency -Tuning Device Adjustable in the Range of 70-200 kHz

Ref.: Instruction Manual

No.: 13842/201

Rev.: 2

Page:

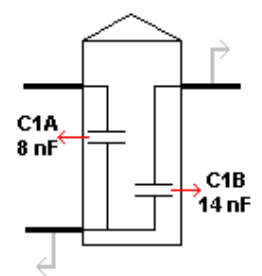
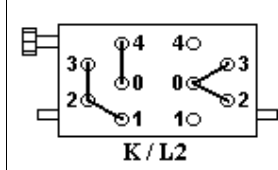
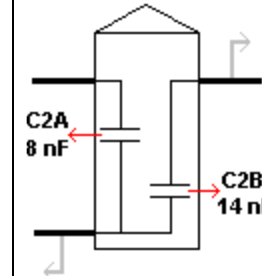
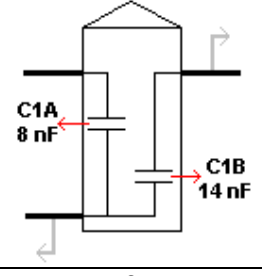
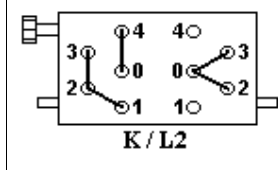
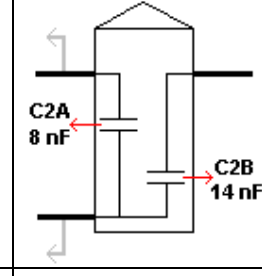
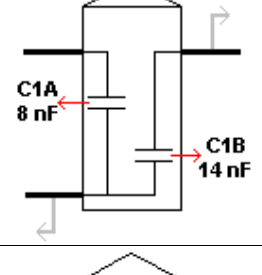
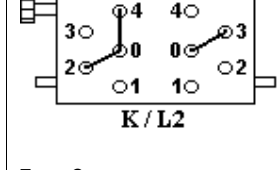
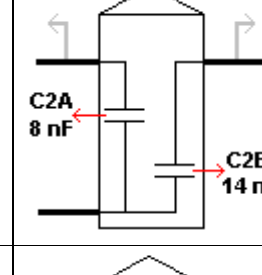
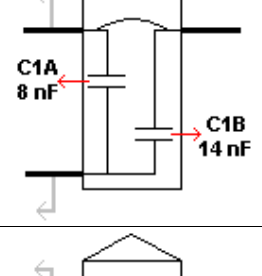
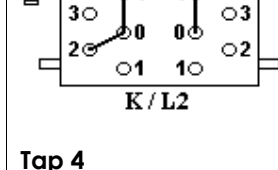
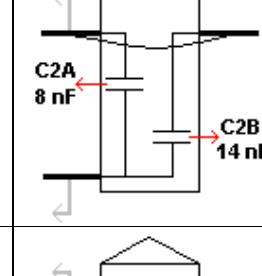
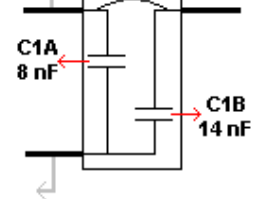
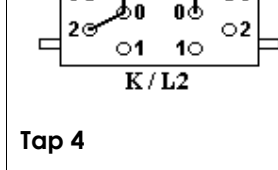
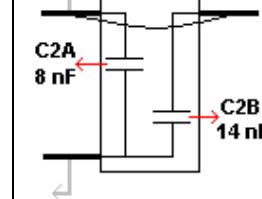
Diagram's Camp	C1		K	L2	C2	
	nF	Connection	nF	Connection	nF	Connection
K	14		25	 Tap 2 or 3	14	
L	14		25	 Tap 2 or 3	8	
M	14		15	 Tap 3	5.1	
N	22		15	 Tap 4	22	
O	22		15	 Tap 4	22	

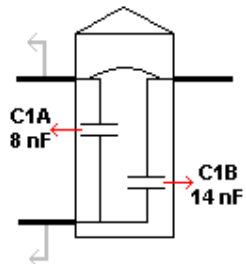
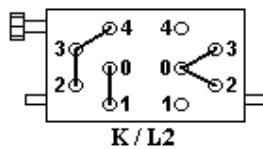
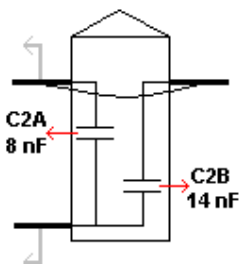
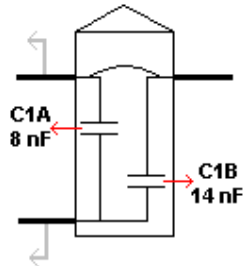
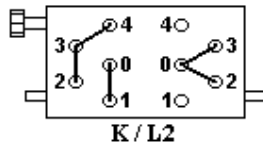
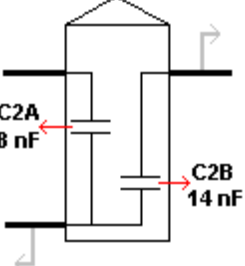
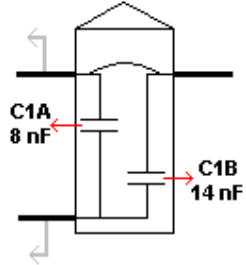
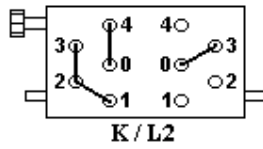
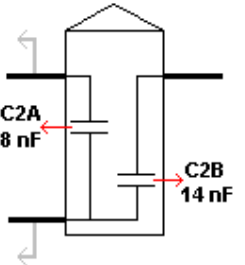
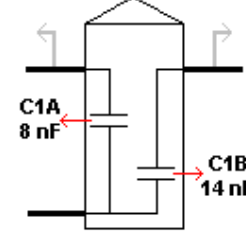
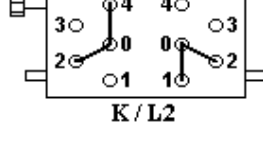
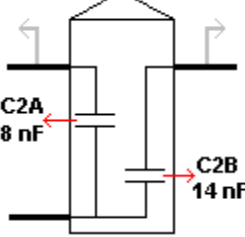
Diagram's Camp	C1		K	L2	C2	
	nF	Connection	nF	Connection	nF	Connection
P	22		40	 Tap 2 or 3	22	
Q	22		40	 Tap 2 or 3	14	
R	22		25	 Tap 3	8	
S	5.1		15	 Tap 1 or 2	5.1	

Title: Instruction Manual for Double Frequency -Tuning Device Adjustable in the Range of 70-200 kHz

Ref.: Instruction Manual

No.: 13842/201

Rev.: 2

Page: