

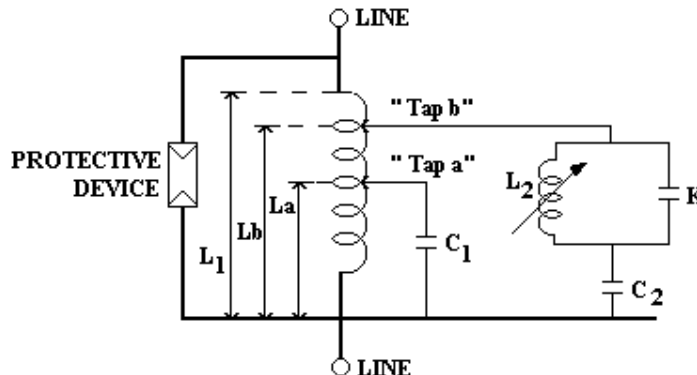

POSITION	EMISSION	APPROVAL	VERSION	CONTROL
DEPT.	SETEL	SETEL	March, 06 of 2006	SEATE
CHECKED	Vagner Lúcio	Flavio Spressola	No.17481 –REV3 3 ^a Edition	Bruno Fonseca
INSTRUCTION MANUAL FOR DOUBLE FREQUENCY - TUNING DEVICE ADJUSTABLE IN THE RANGE OF 50- 150 kHz				Total of pages 11 Page 1

1.0 - DESCRIPTION OF CIRCUIT



In the two frequency trap (shown above) there are two parallel resonant circuits: $L_a - C_1$ and $L_2 - C_2$. There are both resonant at the upper frequency f_1 . The $L_a - C_1$ circuit consists of a capacitance which can be varied in steps and an inductance which can be varied continuously by changing the winding of the main coil.

The high impedance of $L_a - K$ circuit prevents C_2 from shunting the $L_a - C_1$ circuit at f_1 .

At the lower, frequency f_2 , the entire lower branch, K in series with $L_2 - K$, that C_1 tunes the trap to the lower frequency, f_2 , inductance L_b (shown above) is that amount of the main coil L_1 actually inclosed in the f_2 circuit L_b is continuously variable in the same manner as L_a , in the f_1 circuit.

2.0 - ADJUSTMENT

2.1 - The tuning charts on pages 9 to 11 provide nominal capacitance values and approximate L_2 tap settings. No calculations are required. A particular tuning area is located by the point where the capacitance values and tap settings are then read from a table.

It should be noted, however, that the capacitance tolerances will affect the tuning, for this reason, it is sometimes necessary to go a neighboring tuning area from the one where the frequencies intersect. this is described in more detail later

2.2 - 50 - 150 kHz TUNING CHARTS

Figure on page 8 provides tuning informations in the 50 - 150 kHz frequency range. The horizontal line at 150 kHz on the f_1 scale shows the nominal upper frequency limit for f_1 . The vertical dotted line at 50 kHz shown the nominal lower frequency limit for f_2 . The diagonal dotted line represents the nominal lower frequency limit of f_1 for each value of f_2 , or the nominal upper frequency of f_2 for each value of f_1 . The area enclosed by these three lines is the nominal tuning area of the traps. the regions outside the triangular area can be used with certain limitations. In the regions directly below the triangle, the frequency spacing is less than the recommended minimum, tuning may be more difficult, and the trap bandwidth might be reduced. The rest of the region outside the triangle represents the range in which capacitors tolerance could make it impossible to tune the trap to the desire frequency.

2.3 - Figure on page 3 shows atypical curve for a two-frequency traps.

Title:INSTRUCTION MANUAL FOR DOUBLE FREQUENCY - TUNING DEVICE ADJUSTABLE IN THE RANGE OF 50- 150 kHz			
Ref: Instruction Manual	No. 17481	Rev: 3	Page:2/11

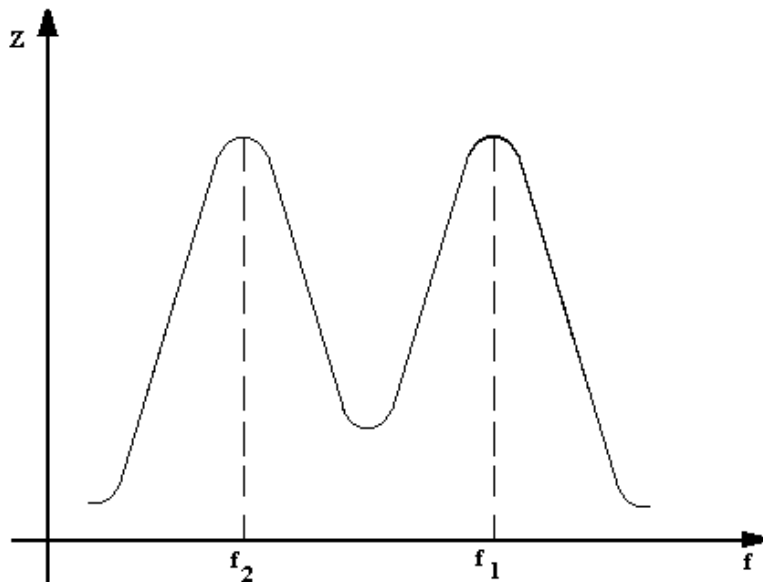

2.4 - In general, the total bandwidth of the two peaks approaches that of the bandwidth of one peak of a single-frequency trap tuned to the geometric mean of the two frequencies, that is $\pm 5\%$ from $\sqrt{f_1 \times f_2}$ considering a 400Ω impedance. If the adjustment charts in this book are followed, the two peaks are usually of approximately equal bandwidth. Occasionally, unfavorable tolerance of the tuning capacitors result in undesirable unequal peaks. Or, the peaks are equal, but unequal peaks are desired in order to favor a wide band carrier channel at expense of a narrow band channel. The re-adjustment procedure included in either of the next two sections may then be tried to obtain area distributions more suitable for the application. This procedure has the objective of transferring area from one curve to the other. It presents a choice of three methods, each of which must be tried to determine if tuning at the desired frequencies can be obtained with the method, and which method gives best results.

2.5 - To Transfer Bandwidth from f_1 to f_2

2.5.1 - Mark the position of the C_1 tap on L_1 for future reference. Choose the next larger value of C_1 and re-tune C_1 - L_1 to f_1 by tapping C_1 further down on L_1 . Mark the tap location for future reference.

2.5.2 - Starting with the original adjustments, choose the next smaller value of C_2 . Re-tune to f_2 by tapping C_2 higher up on L_1 . Mark the tap location for future reference.

2.5.3 - Starting with the original adjustments choose the next larger value of K . Re-tune L_2 to obtain the f_1 dip. Adjust the C_2 tap higher on L_1 to obtain the f_2 dip. If the larger value of C_2 and again adjust C_2 tap.

2.6 - To transfer bandwidth from f_2 to f_1

2.6.1 - Mark the position of the C_1 tap on L_1 for future reference. choose the next smaller value of C_1 and re-tune C_1 - L_1 to f_1 by tapping higher on L_1 .

Title:INSTRUCTION MANUAL FOR DOUBLE FREQUENCY - TUNING DEVICE ADJUSTABLE IN THE RANGE OF 50- 150 kHz			
Ref: Instruction Manual	No. 17481	Rev: 3	Page:3/11

2.6.2 - Starting with the original adjustments, choose the next larger value of C_2 . Tap C_2 further down on L_1 to obtain the f_2 dip. Mark the tap location for future reference.

2.6.3 - Starting with the original adjustments, choose the next smaller value of K . Re-tune L_2 to obtain the f_1 dip. Adjust the C_2 tap lower on L_1 to obtain the f_2 dip. If the dip cannot be reached use the next smaller value of C_2 and again adjust C_2 tap.

2.7 - Minimum spacing between f_1 and f_2

2.7.1 -It is generally desirable that each impedance peak be symmetrical. As the spacing is reduced, dissymetry is introduced. This is quite evident in case of extremely close spacing in figure on page 3. This effect is aggravated by having the C_1 and C_2 taps too far down on L_1 due to careless adjustment.

2.8 - Adjustment

2.8.1 - Locate the upper frequency, f_1 , on the vertical axis of the chart, and draw a horizontal line through the point.

2.8.2 - Locate the lower frequency, f_2 , on the horizontal axis of the chart, and draw a vertical line through the point.

2.8.3 - Note the lettered area in which the two intersect.

2.8.4 - Locate the letter in the case table, and make the specific connections for C_1 , K , C_2 and L_2 .

2.8.5 - Disconnect the L_b tap so that the circuit consist of only L_a and C_1 (See figure on page 2) .

2.8.6 - Make test connections as recommended by the IEC 353 Standards for single-frequency trap adjustment. (See figure below).

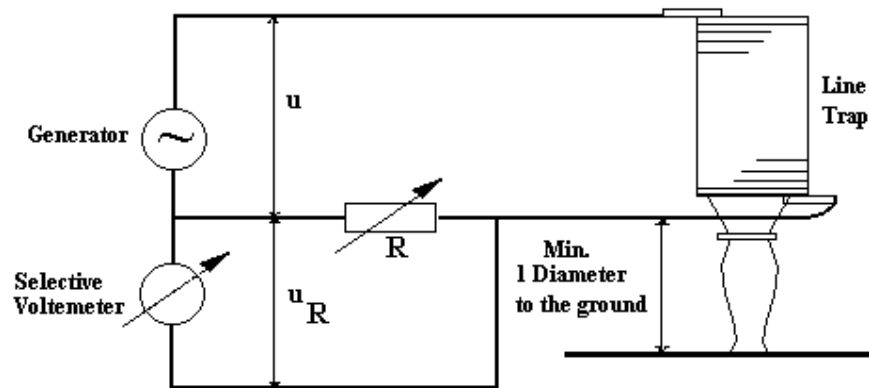

2.8.7 - With the coil tap La on any convenient point, locate the actual resonant frequency by varying the signal generator frequency so that a minimum voltmeter reading is obtained.

If the actual frequency is higher than the required frequency, move the tap in direction of more windings turns.

2.8.8 - If the actual frequency is lower than the required frequency, move the tap in direction of decreased number of winding turns.

2.8.9 - If a case should arise (due to capacitance tolerance) where the full coil is in the circuit and the frequency is still too high, select the next high nominal value of C_1 and readjust the coil tap.

2.8.10 - It is desirable to have as much of the main coil inductance in the circuit as possible. Thus, if the tuning tap is set very far away from the tuning pack end of the trap, a smaller value of C_1 should be chosen and the tap re-adjusted to determine whether the trap can be tuned for the lower value of C_1 . Due to capacitor tolerances and the limited number of capacitance steps available, it may be necessary to lose considerable inductance by tapping down on coil. However, as long as the specified 400Ω impedance is obtained over the bandwidth, the trap is operating satisfactorily. In this case of adjustable tuning from 50 to 150 kHz the bandwidth should be at least $\pm 5\%$ of the geometric mean frequency of adjusted band.

2.8.11 - Connect the " tap b " to any convenient point on the main coil.

2.8.12 - Without changing the signal generator setting adjust the core of the coil L_2 until a minimum voltage U_r is obtained. This tunes the L_2 -K circuit to frequency f_1 .

2.8.13 - Vary the signal frequency until another resonant dip is located on a lower frequency f_2 .

2.8.14 - If this dip is below the desired f_2 frequency, move the L_b tap in the direction of decreased inductance and repeat step 2.8.13.



- 2.8.15** - If the dip of step 2.8.13 is above the desired f_2 frequency, move the Lb tap in the direction of increased inductance and repeat step 2.8.13.
- 2.8.16** - Repeat steps 2.8.13. through 2.8.15. until f_2 frequency is obtained.
- 2.8.17** - If a case should arise (due to capacity tolerances) where the full coil is in the circuit, and the actual frequency is still too high, refer to the adjacent area to the left of the original area on the tuning chart.
- 2.8.18** - Make the connections this area specifies for K, C_2 and L_2 . (In many cases, only C_2 will need to be changed).
- 2.8.19** - If necessary, re-tune the L_2 -K circuit to the upper frequency, f_1 .
- 2.8.20** - Tune the trap to the lower frequency, f_2 , using steps 2.8.13 through 2.8.16.
- 2.8.21** - If the final setting of the Lb tap occurs at a point which is far below 100 percent of the full coil turns, refer to the adjacent area to the right of the original area.
- 2.8.22** - Proceed as in steps 2.8.18 through 2.8.20.
- 2.8.23** -If it is not possible with this set-up to tune the desired f_2 frequency even with the Lb tap in the maximum position, then return to the original chart area and reconnect the circuits K, C_2 and L_2 , adjusted to the original settings.

Title:INSTRUCTION MANUAL FOR DOUBLE FREQUENCY - TUNING DEVICE ADJUSTABLE IN THE RANGE OF 50- 150 kHz			
Ref: Instruction Manual	No. 17481	Rev: 3	Page:6/11

CIRCUIT A

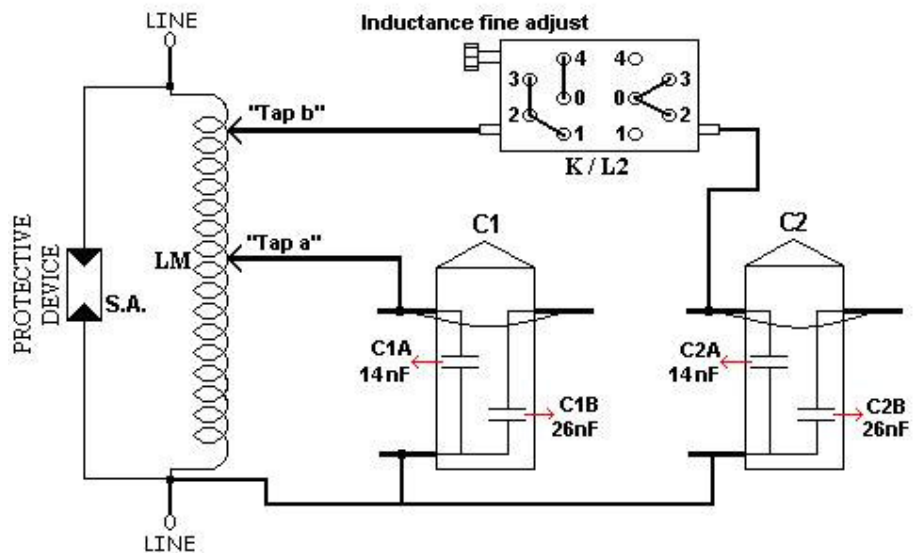

CIRCUIT B

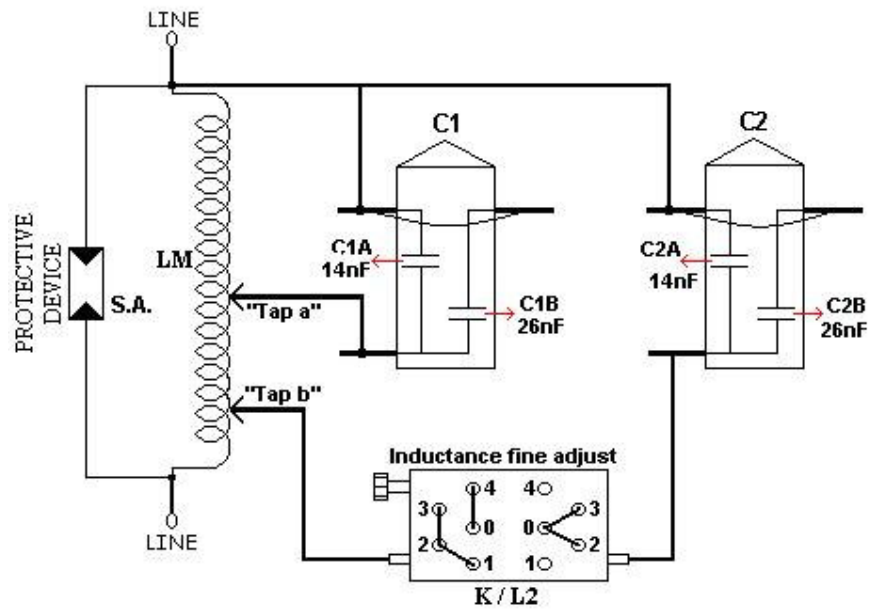

The tuning devices can be connected to circuit A or circuit B.

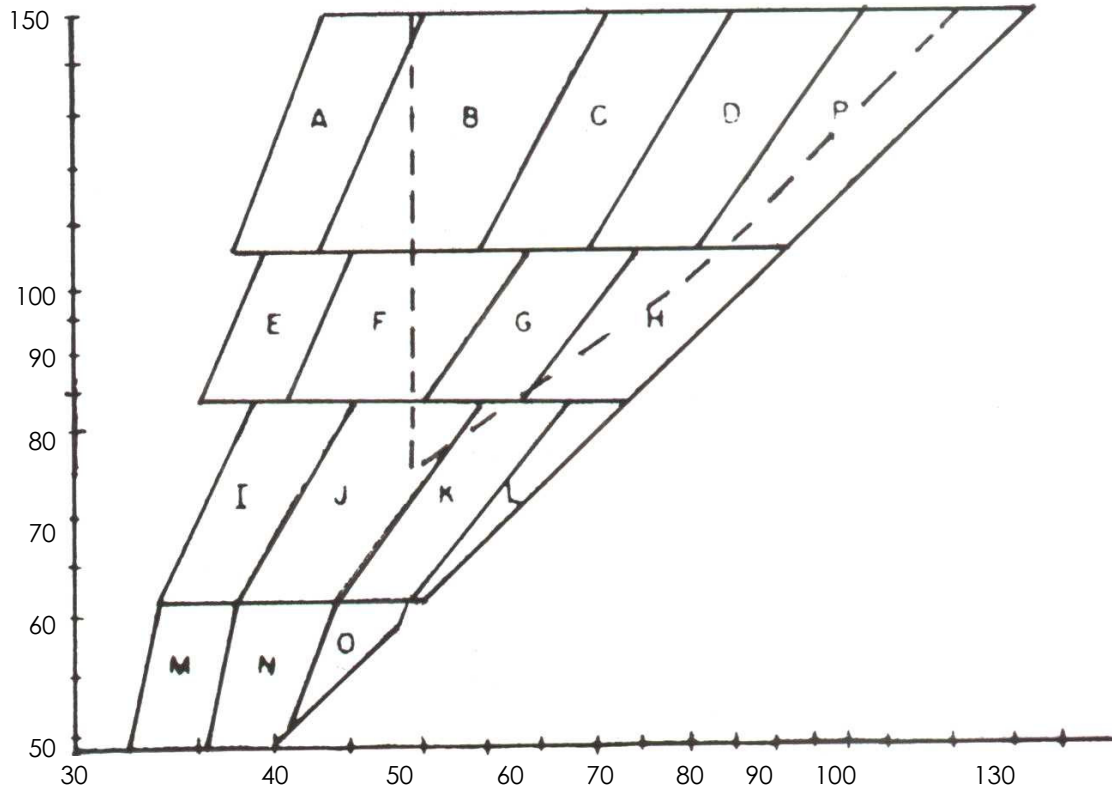

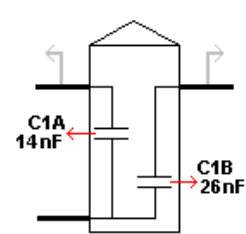
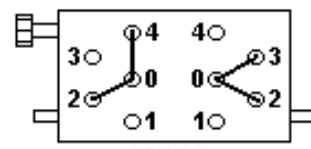
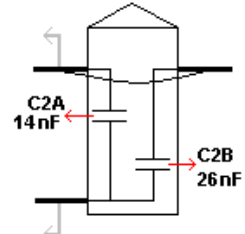
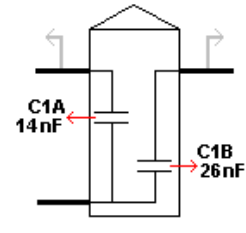
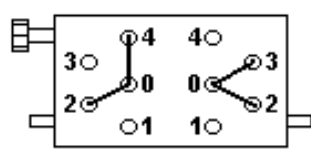
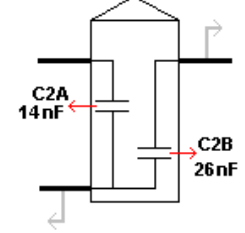
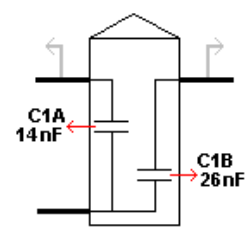
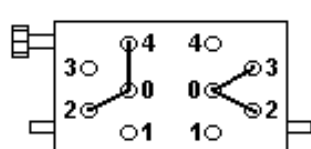
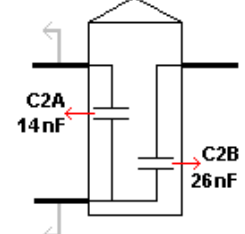
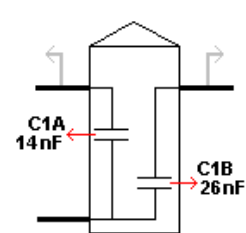
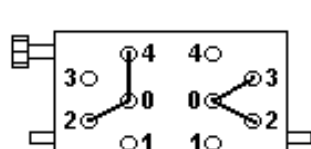
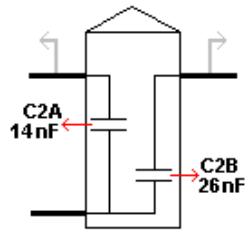
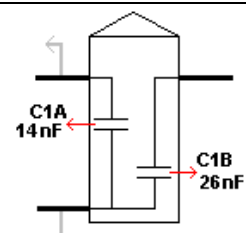
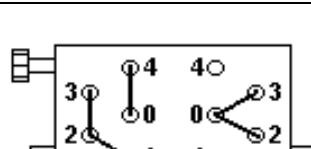
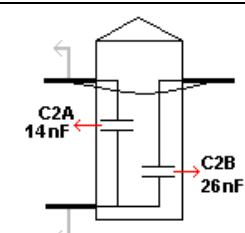
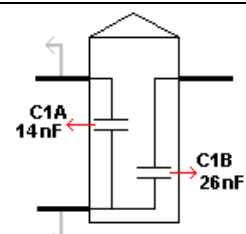
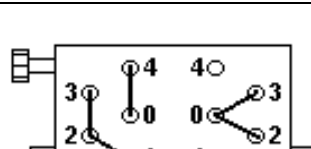
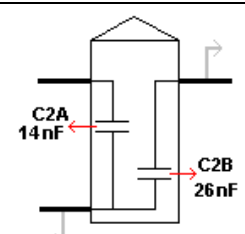
Diagram's Camp	C ₁		K	L ₂	C ₂	
	nF	Connection			nF	Connection
A	9.1		15	 K / L ₂ L ₂ = 2 or 3	40	
B	9.1		15	 K / L ₂ L ₂ = 2 or 3	26	
C	9.1		15	 K / L ₂ L ₂ = 2 or 3	14	
D	9.1		15	 K / L ₂ L ₂ = 2 or 3	9.1	
E	14		25	 K / L ₂ L ₂ = 2 or 3	40	
F	14		25	 K / L ₂ L ₂ = 2 or 3	26	

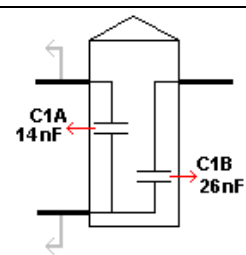
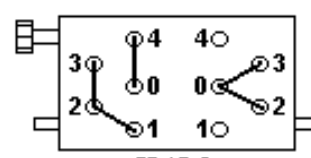
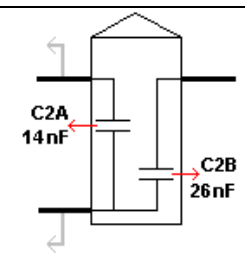
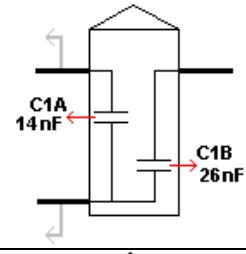
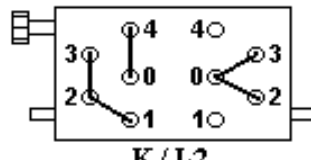
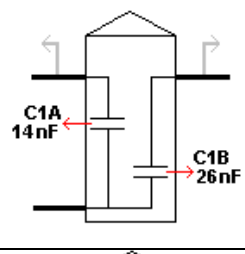
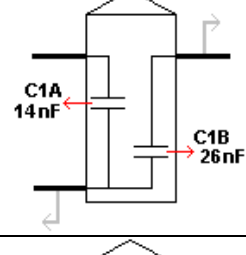
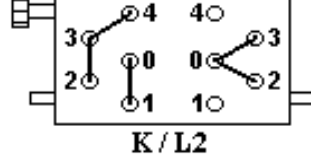
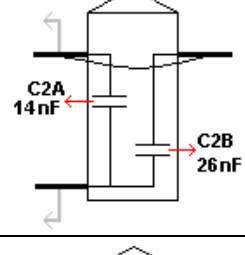
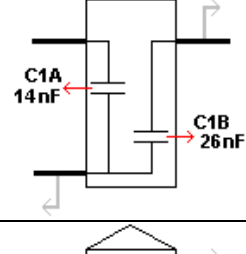
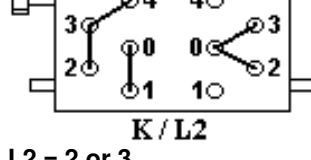
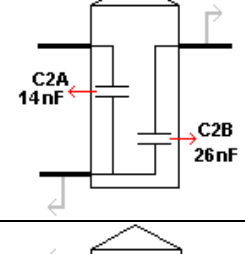
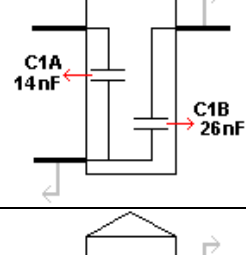
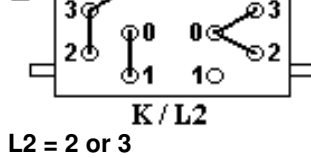
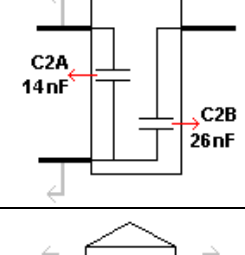
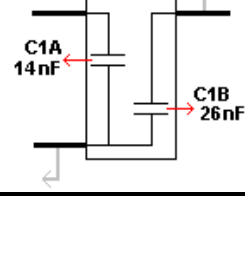
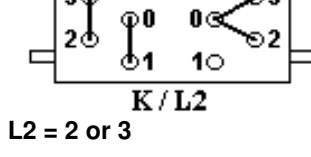
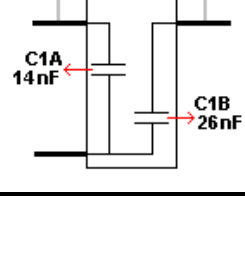
Diagram's Camp	C ₁		K	L ₂	C ₂	
	nF	Connection			nF	Connection
G	14		25	 K / L ₂ L ₂ = 2 or 3	14	
H	14		25	 K / L ₂ L ₂ = 2 or 3	9.1	
I	26		40	 K / L ₂ L ₂ = 2 or 3	40	
J	26		40	 K / L ₂ L ₂ = 2 or 3	26	
K	26		40	 K / L ₂ L ₂ = 2 or 3	14	
L	26		40	 K / L ₂ L ₂ = 2 or 3	9.1	

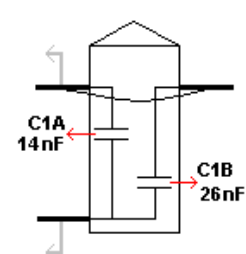
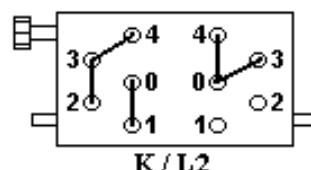
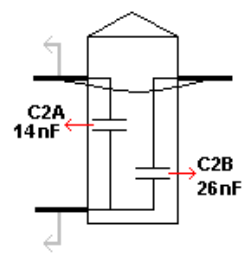
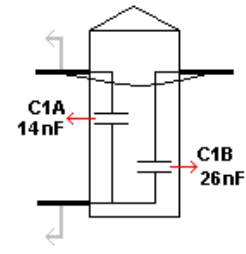
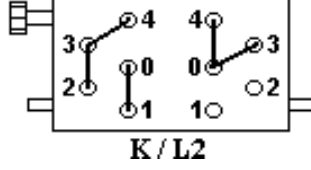
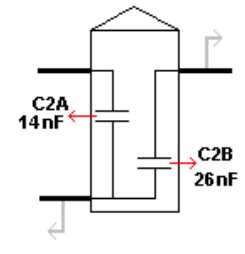
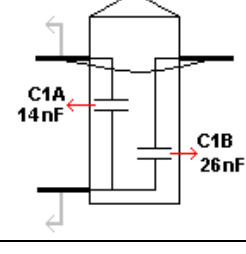
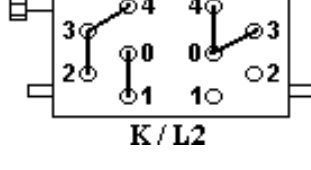
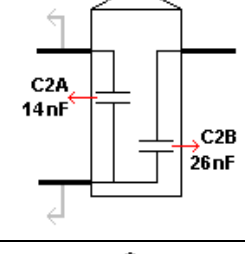
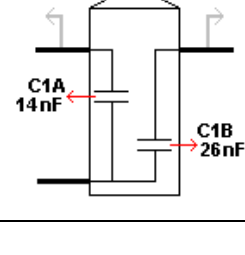
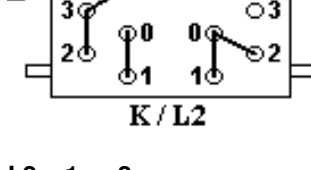
Diagram's Camp	C ₁		K	L ₂	C ₂	
	nF	Connection	nF	Connection	nF	Connection
M	40		40	 L ₂ = 3 or 4	40	
N	40		40	 L ₂ = 3 or 4	26	
O	40		40	 L ₂ = 3 or 4	14	
P	9.1		40	 L ₂ = 1 or 2	9.1	