INSTRUCTION MANUAL

IL-VZFS-R2

VOLTAGE TRANSFORMER

VZF 15...36

1.0 General Description

The VZF voltage transformer is a dry-type, outdoor/indoor unit for line-to-line or line-to-ground installations. The insulation structure utilizes a cycloaliphatic epoxy resin system, which provides excellent electrical and mechanical properties.

2.0 Design Details

2.1 Design

The primary winding, cores and secondary windings are encapsulated with epoxy resin in a single process under vacuum. All outside parts, like the terminal box and mounting plate, are made of corrosion proof materials. For dimensions see the applicable brochure or outline drawing.

2.2 Outer Insulation

Consult the applicable brochure or outline drawing for creepage and strike distances.

2.3 Primary Terminals

The primary terminals are clamp-type connectors, suitable for #10 AWG to #1 AWG, unless otherwise stated on the drawing. The connectors are made of tin-plated copper.

2.4 Secondary Terminal Box

The weatherproof terminal box is made of cast, marine-grade aluminum construction. The box is detachable from the transformer body and has an industry standard hole-pattern. The box has ventilation holes to avoid condensation. These holes may be sealed in the field for horizontal or inverted mounting. One 1" NPT conduit opening is provided on each side of the terminal box and one 1" knockout is provided on the bottom of the box. The secondary terminals are bronze, clamp-type, with a large diameter hole. A ground terminal is also provided. The proper torque value for secondary terminals is 4 foot-pounds.

2.5 Nameplate

The nameplate is made from marine-grade aluminum and is permanently fixed to the mounting plate.

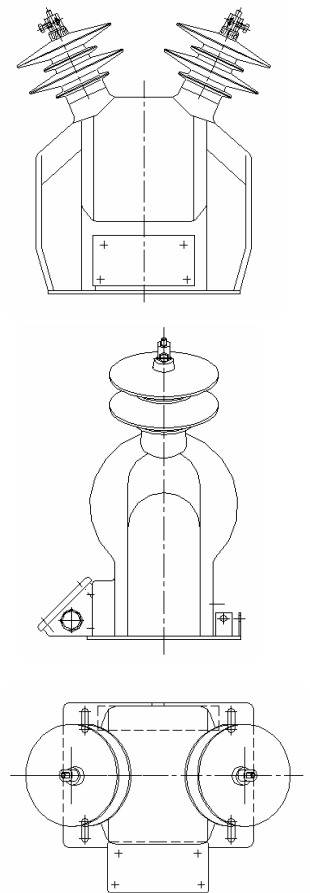

3.0 Installation

3.1 Transport and Lifting

The transformer should be lifted by means of a fabric hoisting sling, as shown in Figure 1. Care should be taken when handling the transformer. The sheds on the outside of the unit should be treated in the same manner as with porcelain insulators.

3.2 Inspection

Before installation, the transformer should be inspected for physical damage that may have occurred during shipment and handling. All insulation surfaces should be considered the same as the surface of porcelain insulators, in regards to cleanliness.

3.3 Mounting

The transformer can be mounted vertically, horizontally, or inverted on a flat surface. Note that the cantilever strength of the unit is reduced when not mounted in the vertical position.

3.4 Primary Connection

The primary terminal surfaces should be clean and free from damage prior to connection. Connect the H1 and H2 terminals to the respective lines or connect the H2 to ground, depending on the rating of the unit.

DANGER: Never energize the unit with just one primary terminal connected.

3.5 Secondary Connection

Connect the secondary to a suitable burden (meter, relay, etc...). If a secondary winding is not used, **one** terminal should be grounded using the grounding bars provided with the unit.

DANGER: NEVER OPERATE THE VOLTAGE TRANSFORMER WITH A SECONDARY WINDING SHORT-CIRCUITED!! HIGH-CURRENT!!

3.6 Ground Connection

Ground the transformer using the one-hole ground pad provided on the mounting plate.

4.0 Maintenance

The transformer is designed to be maintenance-free for the life of the unit. When the transformer is installed in a polluted environment, a regular surface cleaning and treatment is recommended. Acceptable cleaning detergents are acetone or benzene. The surface should then be treated by applying a thin layer of silicone compound (e.g. Dow Corning MS4 Silicone Compound).

5.0 Testing

5.1 Insulation Testing

Per IEEE C57.13 section 8.8.2, field dielectric tests should not be in excess of 75% of the original factory test levels. **Caution:** Induced tests or power-frequency withstand voltage tests (hi-pot) on the primary should be performed with a frequency of 150 Hz or higher to avoid saturation of the core.

Insulation power-factor tests (Doble tests) can be made on dry-type insulation systems, however, these tests are not necessarily indicative as to the state of the insulation system and there can be a wide variance in readings from unit-to-unit.

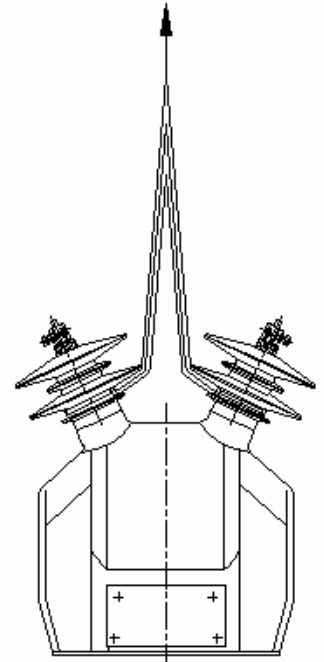

Figure 1