



Line Traps

Air core, dry type
Up to 800 kV

Line traps are used in transmission and distribution networks around the world.

Line traps are a key component in PLC (Power Line Carrier) systems used for remote control signals, voice communication, remote metering and control between substations in the electrical T&D network.

Our engineers have extensive experience in designing and supplying line traps for system voltages up to 800 kV, and the company has supplied customers all over the world for more than 25 years.



Customer benefits

- High short-circuit withstand capability
- Light weight
- Reliable open-style design (OSD)
- Mounting flexibility
- Excellent cooling
- Extremely reliable tuning devices
- Self-resonance frequency greater than 500 kHz
- Maintenance-free design

PERFORMANCE

- Up to 800 kV
- Can operate within the 30 kHz to 500 kHz frequency range

CHARACTERISTICS

- Air core, dry type
- Outdoor use
- Compliance with IEC, ANSI or equivalent standard
- Mounting flexibility: vertical on top of Capacitor Voltage Transformer (CVT), vertical on top of insulator columns, horizontal or suspension.



Your Partner in Line Traps

High voltage transmission lines are also used for transmitting carrier signals between 30 kHz and 500 kHz for remote control, voice communication, remote metering & protection, and so forth, and are often referred to as Power Line Carrier (PLC) systems.

Line traps prevent transmission of these high frequency signals to unwanted directions without loss of energy at power frequency.

Line traps are series-connected to the transmission lines, and are designed to withstand the rated power frequency current and the short-circuit current to which the lines are subjected.

CONSTRUCTION

Main coil

The main coil carries the rated current of the transmission line and is designed to withstand the maximum short-circuit current. Its winding consists of high mechanical strength aluminum profiles of rectangular cross section. Depending on the current, one or more profiles are connected in parallel. Each turn is separated by fiberglass-reinforced spacers. The winding is held together by aluminum cross arms at the top and bottom end of the main coil, and one or more fiberglass insulated tie rods.

The main coil is mechanically robust and lightweight.

The main coil is an open, air-insulated spool and therefore offers excellent cooling properties.

Due to this design, no surface cracking will occur.

Its low self-capacitance provides a high self-resonance frequency making it particularly suitable for high frequency applications, such as PLC.

These important characteristics ensure excellent performance, in particular, in the event of a short-circuit. As a result, a long service life is obtained.

Extremely reliable tuning devices

This key sub-component of a line trap is mounted inside the main coil on the central tie rod. It is easily accessible and exchangeable. It can be replaced without removing the line trap from the line. All components are chosen to ensure exceptional operating reliability and a long service life.

The tuning device can be factory fixed or field adjustable, designed for single-frequency, double-frequency or wide-band tuning. In addition, the tuning device can be furnished for use in line traps of other manufacturers.

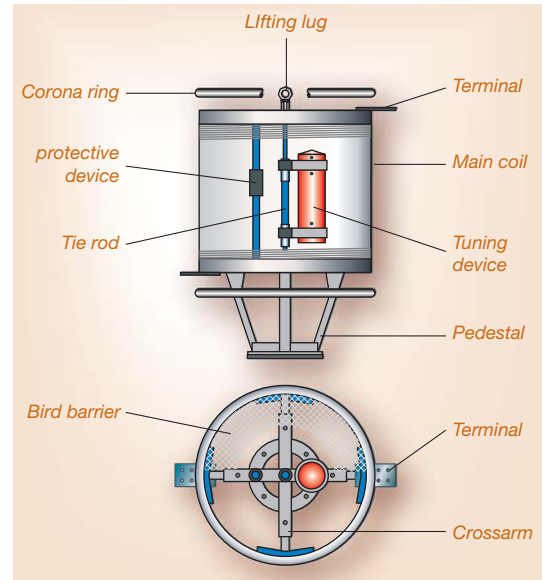

Fig. 1: Line trap main components

All components are encapsulated in a triple weather-protection housing resistant to ever-changing environmental conditions and mechanical shocks. The temperature coefficients of the tuning device elements are chosen to yield a very high degree of tuning consistency.

Protective Device

The protective device is connected across the main coil and the tuning device to prevent the line trap from being damaged by transient overvoltages. Its ratings are chosen to respond to high transient overvoltages, but it will not operate as a result of the power frequency voltage developed across the line trap by the rated short-circuit, nor will it remain in operation after the response to a transient overvoltage developed across the line trap by the rated short-circuit.

Gapless (or gapped) metal-oxide (ZnO) or gapped silicon carbide (SiC) types are used depending on the line trap characteristics.

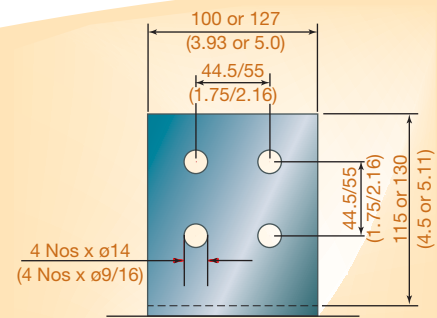

Thickness = 13 (0.5) (Min)

Note : dimensions are in mm (inches)

Fig. 2A: Terminals details

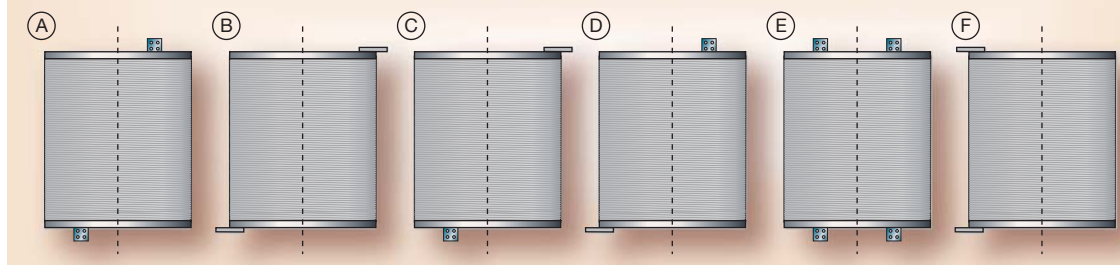

Fig. 2B: Terminals arrangements

MOUNTING

Suspension Mounting

All line traps are equipped with a lifting lug, which is bolted directly to the central tie rod. For this type of mounting, an eyebolt is similarly added to the bottom cross arm to anchor the line trap and prevent swaying. Two, three or four-point suspension can be provided upon request (see fig. 3 page 4).

Pedestal Mounting

Vertical Mounting

For this type of mounting, the line traps feature an aluminum pedestal. The pedestals have adequate height to prevent excessive heating of the post insulator or coupling capacitor voltage transformer (CCVT) fittings due to the magnetic field of the main coil.

Small or medium sized line traps can be mounted directly on a single post insulator or CCVT by using a pedestal (vertical pedestal A type).

Standard bolt circle mounting diameters (BCD), Dfa, are 296 mm (11.65"), 220 mm (8.66") and 127 mm (5"). Other BCD's can be provided upon request. For large sized line traps, the use of the three insulator columns pedestal (vertical pedestal B type) is recommended. Standard bolt circle mounting diameters (BCD), Dfb, are 1000 mm (39.4") for line traps with Ds = 1396 mm (55") and 1395 mm (54.9") for line traps with Ds = 1846 mm (72.7").

The number of columns and other mounting details of the vertical pedestal B type can be adapted to meet customer requirements (see fig. 4 page 4).

Horizontal Mounting

Given that the open style winding offers an equally effective cooling property in the horizontal position as in the vertical, the line traps are adequate for operation

in the horizontal position. The line traps are furnished with two or four aluminum pedestals mountable on base flanges with eight 18mm (11/16") diameter holes to fit 127 mm (5") or 178 mm (7") BCD's or other patterns upon request (see fig. 5 page 4).

Terminals

The line traps are supplied with 4-hole NEMA flat pad aluminum terminals (refer to fig. 2A for details). For copper connectors, tin-plated copper adapter plates are provided. Other hole patterns are available upon request. The number of terminals and cross-section depend on the rated current of the line trap (refer to fig. 2B for typical terminal arrangements).

Mechanical Strength of Terminal

Permissible static line pull in longitudinal direction: 2940N.

Permissible static bending load applied in the center of the terminal: 2450N.

Nameplates

Aluminum or stainless steel nameplates are supplied.

Bird barriers

Bird barriers prevent the intrusion of birds into the main coil. The bird barriers consist of a temperature and UV resistant fiberglass reinforced plastic grid with square-shaped 15x15 mm openings. The bird barrier does not adversely affect the cooling of the line trap.

Surface Finish

The surface is first cleaned by sandblasting. A finishing coat of alkyd-enamel to a minimum thickness of 30 µm (1.2 mils) in Munsell N6.5 (ANSI 70) grey is applied. Special customer requirements can be accommodated.

Thermal Strength

The line traps are designed for temperature Class F (155 °C) according to IEC 353 (1989) and Insulation Temperature Index of 155 °C according to ANSI C93.3-1981. These standards allow a temperature rise of 115 °C (measured by the resistance method) and a maximum temperature rise of 135 °C (hot spot) above the mean ambient temperature.

Nevertheless, the line traps are designed to display an average temperature rise of only 80 °C at rated current at a power frequency of 50 Hz. This makes it possible to use the same line trap on 60 Hz networks at a continuous ambient temperature of 45 °C.



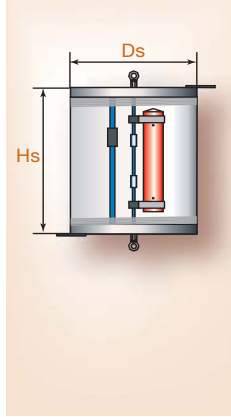

Fig. 3: Vertical suspension

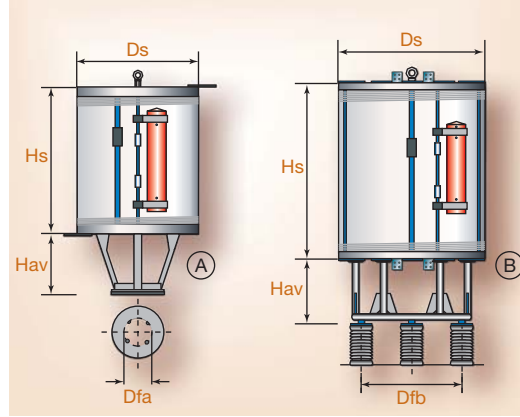

Fig. 4: Vertical pedestal A & B

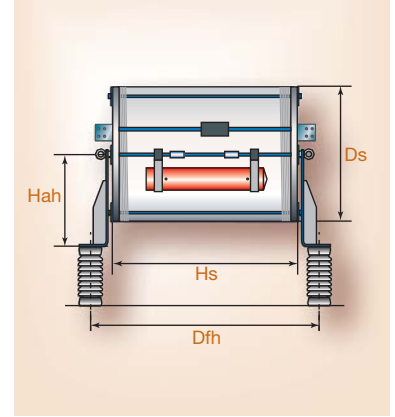

Fig. 5: Horizontal pedestal

ACCESSORIES

In addition to the standard design consisting of a main coil, a tuning device and a protective device, the following accessories are available upon request:

- Line connectors (aluminum or bi-metal), for direct connection of the high voltage conductor
- Corona rings are usually not required for system voltages up to 245 kV, given that no special corona discharge requirement is imposed. Should corona rings be required, rings constructed of aluminum tubes (diameter of 38 mm = 1 1/2") are provided. In this case, the overall diameter of the line trap is increased by 40 mm and the coil height by 2x100 mm. In case of pedestal mounting, the overall height is only increased by 100 mm, because the lower corona ring protrudes over the pedestal.

TESTS

The following routine (production) tests are applicable:

IEC

- Measurement of rated inductance of the main coil (at 100 kHz)
- Measurement of power frequency inductance of the main coil (at 100 Hz)
- Power-frequency dielectric withstand test on tuning device
- Measurement of blocking impedance or blocking resistance or tapping loss or tapping loss based on the blocking resistance

ANSI

- Measurement of main coil true inductance (at 100 Hz & 100 kHz)
- Sparkover test of auxiliary protective devices
- Measurement of blocking impedance
- Measurement of tuning device component values
- Power-frequency dielectric withstand test on tuning device

Testing

The routine testing program for the line traps is performed with a measuring system specifically developed for this purpose.

Frequency response curves can be plotted for the resistive component, impedance, blocking attenuation or tapping loss according to the user-defined settings.

Type (Design) Tests

The most common type (design) tests are: temperature rise, measurement of radio influence voltage (RIV) and short-circuit.

Numerous type tests have been performed at recognized laboratories around the world, such as KEMA (Holland), CESI (Italy), CEPEL (Brazil), (Canada), LAPEM (Mexico) and CPRI (India). Type test reports are available upon request.



Vertical pedestal A line traps featuring line connection at the top

LINE TRAPS ACCORDING TO ANSI STANDARD												
Line trap type	L (mH)	I (A)	Isc (kA) - 2s	Isc (kAp)	Ds (in)	Hs (in)	Hav (in)	Hah (in)	Dfh (in)	Weight (lbs)	Pedestal weight (lbs)	Suggested vertical mounting
0.265/400/15-2	0.265	400	15	38.3	21.5	23.6	9.8	15.7	32.0	165	11	A
0.265/800/20-2	0.265	800	20	51.0	31.3	25.3	14.8	21.1	28.1	220	22	A
0.265/1200/36-2	0.265	1200	36	91.8	31.3	41.5	14.8	21.1	44.1	374	22	A
0.265/1600/44-2	0.265	1600	44	112	41.2	53.5	19.7	25.9	57.4	540	22	A
0.265/2000/63-2	0.265	2000	63	161	41.9	55.5	19.7	27.8	67.9	870	22	A
0.265/3000/63-2	0.265	3000	63	161	55.0	74.0	26.6	31.5	88.9	1101	77	A
0.265/4000/80-2	0.265	4000	80	204	72.7	70.0	31.5	44.5	81.3	1394	99	B

Notes:

1. Dimensions of line traps which are not indicated in the above table can be informed upon request.
2. Line trap type designation: Rated inductance (mH)/Rated current (A)/Rated short-time current (kA) -2 (duration) (e.g. 0.265/1200/36-2:0.265 mH 1200 A 36 kA 2 seconds).
3. The Dfa dimension can be accommodated to meet customer's requirement. Typical values are 11.65", 8.66" and 5" BCD.
4. The Dfb dimension is 39.4" for line traps with Ds=55" and 54.9" for line traps with Ds=72.7".
5. Line traps can be mounted in either vertical suspended, vertical pedestal or horizontal position, as illustrated.
6. The indicated pedestal weights refer to the suggested vertical mounting.



Details of line trap showing bird barrier, crossarms and corona ring

LINE TRAPS ACCORDING TO IEC STANDARD														
Line trap type	L (mH)	I (A)	L _{th} (kA)		L _m (kAp)		Ds (mm)	Hs (mm)	Hav (mm)	Hah (mm)	Dfh (mm)	Weight (kg) approx.	Pedestal weight (Kg)	Suggested vertical mounting
			IEC I	IEC II	IEC I	IEC II								
0.1/400/...	0.1	400	10	16	25.5	41	546	267	250	400	324	35	5	A
0.2/400/...	0.2	400	10	16	25.5	41	546	387	250	400	444	45	5	A
0.32/400/...	0.32	400	10	16	25.5	41	546	507	250	400	564	52	5	A
0.5/400/...	0.5	400	10	16	25.5	41	546	687	250	400	744	65	5	A
1.0/400/...	1	400	10	16	25.5	41	796	738	375	535	795	105	10	A
2.0/400/...	2	400	10	16	25.5	41	796	1188	375	535	1252	155	10	A
0.1/630/...	0.1	630	16	20	41	51	546	321	250	400	371	45	5	A
0.2/630/...	0.2	630	16	20	41	51	546	506	250	400	560	60	5	A
0.32/630/...	0.32	630	16	20	41	51	546	672	250	400	729	80	5	A
0.5/630/...	0.5	630	16	20	41	51	796	616	375	535	673	95	10	A
1.0/630/...	1	630	16	20	41	51	796	967	375	535	1031	145	10	A
2.0/630/...	2	630	16	20	41	51	1046	1190	500	708	1348	205	10	A
0.1/800/...	0.1	800	20	25	51	64	546	489	250	400	546	50	5	A
0.2/800/...	0.2	800	20	25	51	64	546	801	250	400	858	75	5	A
0.32/800/...	0.32	800	20	25	51	64	796	707	375	535	764	100	10	A
0.5/800/...	0.5	800	20	25	51	64	796	967	375	535	1031	130	10	A
1.0/800/...	1	800	20	-	51	-	1046	1179	500	708	1469	180	10	A
1.0/800/...	1	800	-	25	-	64	1046	1431	500	708	1721	240	10	A
2.0/800/...	2	800	20	-	51	-	1396	1363	675	800	1653	295	25	A
2.0/800/...	2	800	-	25	-	64	1396	1639	675	800	1929	365	25	A
0.1/1250/...	0.1	1250	31	40	80.5	102	546	830	250	400	894	80	5	A
0.2/1250/...	0.2	1250	31	40	80.5	102	796	830	375	535	886	125	10	A
0.32/1250/...	0.32	1250	31	40	80.5	102	796	1162	375	535	1233	170	10	A
0.5/1250/...	0.5	1250	31	40	80.5	102	1046	1181	500	708	1471	210	10	A
1.0/1250/...	1	1250	31	-	80.5	-	1396	1394	675	800	1684	335	25	A
1.0/1250/...	1	1250	-	40	-	102	1414	1394	675	800	1684	410	25	A
2.0/1250/...	2	1250	31	-	80.5	-	1846	2104	800	1129	2420	678	50	B
2.0/1250/...	2	1250	-	40	-	102	1846	2104	800	1129	2420	865	50	B
0.1/1600/...	0.1	1600	40	50	102	127.5	796	811	375	535	868	110	10	A
0.2/1600/...	0.2	1600	40	50	102	127.5	1046	1023	500	708	1093	170	10	A
0.32/1600/...	0.32	1600	40	-	102	-	1046	1387	500	708	1477	210	10	A
0.32/1600/...	0.32	1600	-	50	-	127.5	1396	1142	675	800	1232	285	25	A
0.5/1600/...	0.5	1600	40	-	102	-	1396	1363	675	800	1453	295	25	A
0.5/1600/...	0.5	1600	-	50	-	127.5	1396	1505	675	800	1595	360	25	A
1.0/1600/...	1	1600	40	-	102	-	1396	2448	675	800	2538	780	35	A
1.0/1600/...	1	1600	-	50	-	127.5	1414	2448	675	800	2538	820	45	B
2.0/1600/...	2	1600	40	-	102	-	1846	2753	800	1129	2873	850	45	B
2.0/1600/...	2	1600	-	50	-	127.5	1864	2753	800	1129	2873	1100	45	B
0.1/2000/...	0.1	2000	40	50	102	127.5	796	1045	375	535	1109	130	10	A
0.2/2000/...	0.2	2000	40	50	102	127.5	1046	1222	500	708	1303	205	10	A
0.32/2000/...	0.32	2000	40	50	102	127.5	1046	1701	500	708	1792	280	10	A
0.5/2000/...	0.5	2000	40	-	102	-	1396	1670	675	800	1790	380	35	A
0.5/2000/...	0.5	2000	-	50	-	127.5	1414	1505	675	800	1625	550	35	A
1.0/2000/...	1	2000	40	-	102	-	1396	2448	675	800	2535	780	35	A
1.0/2000/...	1	2000	-	50	-	127.5	1846	2615	800	1129	2735	990	50	B
2.0/2000/...	2	2000	40	-	102	-	1864	3052	800	1129	3172	1320	50	B
0.1/2500/...	0.1	2500	40	50	102	127.5	1046	1033	500	708	1094	180	10	A
0.2/2500/...	0.2	2500	40	50	102	127.5	1046	1699	500	708	1780	280	10	A
0.32/2500/...	0.32	2500	40	50	102	127.5	1396	1653	675	800	1718	420	35	A
0.5/2500/...	0.5	2500	40	50	102	127.5	1396	2245	675	800	2330	580	35	A
1.0/2500/...	1	2500	40	50	102	127.5	1846	2615	800	1129	2735	990	50	B
2.0/2500/...	2	2500	40	-	102	-	1864	3110	800	1129	3251	1155	50	B
0.1/3150/...	1.0	3150	40	50	102	127.5	1396	917	675	800	974	230	35	A
0.2/3150/...	0.2	3150	40	50	102	127.5	1396	1519	675	800	1583	345	35	A
0.32/3150/...	0.32	3150	40	50	102	127.5	1396	2149	675	800	2250	495	35	A
0.5/3150/...	0.5	3150	40	50	102	127.5	1846	2060	800	1129	2161	615	45	B
1.0/3150/...	1	3150	40	50	102	127.5	1846	3410	800	1092	3551	1100	50	B

Notes:

- Dimensions of line traps which are not indicated in the above table can be informed upon request.
- Line trap type designation: rated inductance (mH) / Rated current (A) / Mechanical short-time current (kAp) (e.g. 0.32/800/64 : 0.32 mH 800 A 64 kAp - IEC II).
- The Dfa dimension can be accommodated to meet customer's requirement. Standard values are 296 mm, 220 mm and 127 mm BCD.
- The Dfb dimension is 1000 mm for line traps with Ds=1396 mm and 1396 mm for line traps with Ds=1846 or 1864 mm.
- Any line trap can be designed to be mounted in either vertical suspended, vertical pedestal or horizontal position, as illustrated.
- The indicated pedestal weights refer to the suggested vertical mounting.
- Tolerance on dimensions +/- 5% to be included.
- Rated currents from 3150 to 5000A, special design upon request.



High Frequency Characteristics of Line Traps

The frequencies normally used for high-frequency carrier transmission range from 30 kHz to 500 kHz. The purpose of the line trap is to block specific frequency bands within this frequency range.

Certain characteristic values such as impedance or resistive component of the impedance must remain above a given minimum value within a specified bandwidth.

Resistive Component

The main component of the high-frequency characteristics of a line trap is the resistive part of the impedance, also called the resistive impedance. This value is inherent to the line trap. In contrast, attenuation or tapping loss values always represent a comparison.

The main advantage and reason for using the resistive component, as a basis for evaluation is the fact that this value indicates the lowest line trap impedance under any operating condition, including the presence of a full or partial series resonance. If a sufficient high ohmic component is attained, the problem of series resonance is eliminated in carrier transmissions. The possibility of excluding the occurrence of series resonance is of particular importance. In its tuned frequency range, each line trap has inductive and capacitive components. Each reactive component of the line trap impedance can be compensated by the corresponding component of the substation or of the network impedance. The series connection of the two impedances then forms a series resonant circuit whose inherent frequency can be any carrier frequency. In this case, and in the lack of a sufficient resistive component of the line trap impedance, almost the entire high-frequency energy is discharged, a phenomenon which will have adverse effects on carrier transmissions. To prevent this occurrence, the line traps are delivered with suitable tuning devices so that the line trap impedance will always include the necessary resistive component in each specified frequency range.

Attenuation Modes

The evaluation of line traps based on tapping loss and blocking attenuation must be mentioned. This involves a comparison of the line trap impedance at a specific frequency with the impedance of the network as viewed from the line trap installation site.

Depending on the standards applied, the line impedance (characteristic impedance) is assumed to be between 300 and 600 ohms (400 ohms in the case of phase-to-ground coupling and 600 ohms for phase-to-phase coupling), providing a uniform basis for comparison purposes. The tapping (insertion) loss, A_t , and the blocking attenuation, A_b , are distinct parameters to measure the line trap efficiency. Both values are derived from a voltage ration and are expressed either in nepers or in decibels and can be obtained from the following formulas:

$$A_t = \ln \left| 1 + \frac{Z_L}{2Z_1} \right|_{(Np)} \text{ and } A_b = \ln \left| 1 + \frac{Z}{Z_1} \right|_{(Np)}$$

Where:

A_t = tapping loss

Z_L = line impedance (Ω)

Z = line trap impedance (Ω)

A_b = blocking attenuation

Z_1 = network impedance (normally 400 Ω for single-phase coupling and 300 Ω for two-phase coupling)

1 Np = 8.7 dB

High-frequency Characteristics of the Main Coil

The open, air-insulated, single-layer design of the main coil results in small inherent capacitances of 30 to 100 pF, depending on the size of the line traps, and features very high self-resonance frequencies. Furthermore, the specific value of these inherent capacitances is practically constant due to the small production tolerances in terms of coil diameter and winding distance. When using AREVA line traps, it is possible to exchange a tuning device in the event of a frequency range alteration without removing the main coil from the line.

Line Traps with Single-frequency Tuning

When a capacitor is connected in parallel to a relatively low inductance, the result is a resonant circuit with a high impedance Z at the resonance frequency, f_r . The circuit has a very selective operating bandwidth. This tuning device offers a very low resistive component of the impedance at the bandwidth limits but in turn, delivers a very high blocking impedance at the resonance frequency (sample of response curve shown in fig. 6 page 8).



Horizontal pedestal line trap with corona ring

The desired minimum resistive component of the impedance is obtained by damping the parallel resonant circuit, i.e. by adding a resistor in series with the tuning capacitor.

The minimum resistive component of the blocking impedance in the single-frequency tuning mode is obtained using the following formulas:

$$R_{min} = k \cdot \pi \cdot L \frac{f_2 \cdot f_1}{f_2 - f_1} \quad Z_{min} = \sqrt{2} \cdot k \cdot \pi \cdot L \frac{f_2 \cdot f_1}{f_2 - f_1}$$

f _r (kHz)	Factor k
20	0.75
25	0.76
30	0.77
35	0.78
40	0.79
50	0.82
60	0.85
70	0.87
80	0.88
90	0.89
≥100	0.90

$$f_r = \sqrt{f_2 \cdot f_1}$$

f₁ = lower band limit

f₂ = upper band limit

where k is determined from the below table (intermediate values of f_r can be interpolated):

Line traps with Wide band Tuning

At a same geometric mean (f_r), the main coil provides twice the bandwidth of an equivalent single-frequency tuning device. The minimum resistive component occurs at the limits and in the center of the blocked bandwidth (sample of response curve shown in fig. 7 page 8).

The minimum resistive component of the blocking impedance and the minimum impedance in the wide band tuning mode are obtained using the following formulas:

$$R_{min} = k \cdot 2\pi \cdot L \frac{f_2 \cdot f_1}{f_2 - f_1}$$

$$Z_{min} = \sqrt{2} \cdot k \cdot 2\pi \cdot L \frac{f_2 \cdot f_1}{f_2 - f_1}$$

where k is determined from the same table as for single-frequency tuning.

Note: Increased bandwidths can be obtained by use of a special wide band tuning circuit, as illustrated in fig. 8 page 8.

Line traps for double-frequency tuning

Double-frequency tuning devices can be used to block two non-adjacent frequencies (sample of response curve shown in fig. 9 page 8).

Field-adjustable tuning devices

Field-adjustable tuning devices can be single-frequency, double-frequency or wide-band tuned. This kind of tuning is considered when there is a need to modify the frequency range of the line trap after its installation on the site.

Inquiry check list:

- > Rated inductance
- > Rated current
- > Rated power frequency
- > System voltage
- > Rated short-circuit current
- > Tuning device type
- > Tuning range
- > Minimum blocking impedance or resistance
- > Mounting requirements
- > Terminal arrangement
- > Installation conditions (e.g. seismic requirements, wind speed, ambient temperature if over 45 °C, operating altitude if more than 1000 m (3300ft) above sea level)



Vertical pedestal A line trap mounted on CCVT



Vertical pedestal B line trap



Line Traps

Air core, dry type
Up to 800 kV

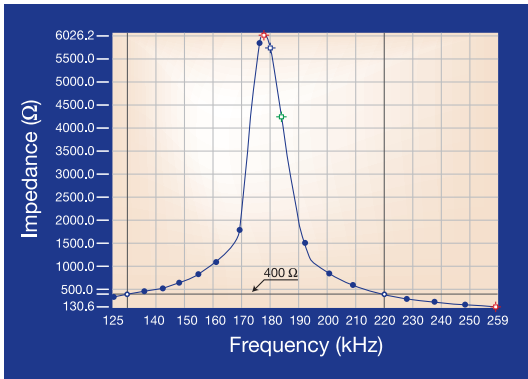

Fig. 6: sample response curve of single-frequency tuning.

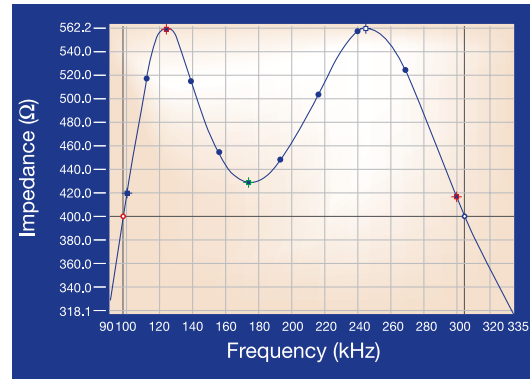

Fig. 7: Sample response curve of wide band tuning.

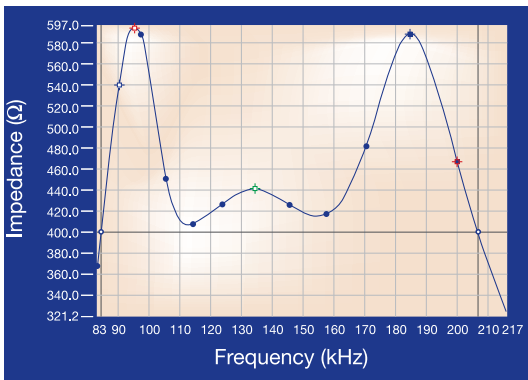

Fig. 8: Sample response curve of a special wide band tuning circuit.

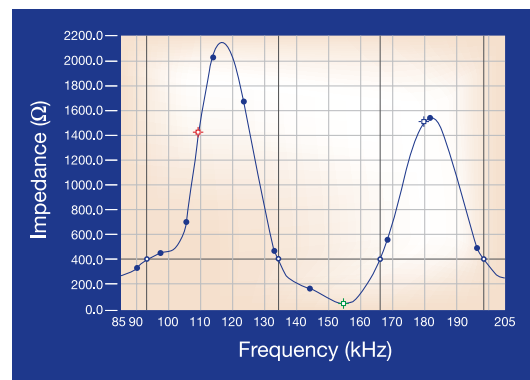

Fig. 9: Sample response curve of double-frequency tuning.



AREVA T&D Worldwide Contact Centre :
<http://www.aveva-td.com/contactcentre/>
Tel.: +44 (0) 1785 250 070

www.aveva-td.com

Our policy is one of continuous development. Accordingly the design of our products may change at any time. Whilst every effort is made to produce up to date literature, this brochure should only be regarded as a guide and is intended for information purposes only. Its contents do not constitute an offer for sale or advise on the application of any product referred to in it. We cannot be held responsible for any reliance on any decisions taken on its contents without specific advice.